

N1094A/B DCA-M

Electrical Sampling Oscilloscopes

High Accuracy, Low Cost Solutions

For electrical waveform analysis,

- Solutions for up to 56 Gb/s
- Very low noise and jitter
- Fast sampling rates for high throughput

Legendary DCA Accuracy

The Keysight Technologies, Inc. N1000 and 86100 digital communication analyzer (DCA) family is recognized as the industry standard for verifying optical transmitter compliance to communications standards. For years engineers have trusted the DCA to provide accurate and easy measurement of digital communication waveforms. The Keysight N1094A/B DCA-M has built on that legacy by using the high-performance elements of both the 86100 oscilloscope mainframe acquisition system and the optical and electrical channel hardware of the 861XX and N104X plug-in modules.

Small Form Factor for Both Manufacturing and R&D Applications

Unlike the N1000 and 86100, which use modules to create a waveform analysis system, the N1094A/B are completely integrated instruments built in a small form factor. Electrical channels are available with 30 GHz and 50 GHz bandwidths.



User Interface

The N1094A/B user interface and operating system is identical to the modern FlexDCA interface of the N1000A and 86100D. A user-provided PC running N1010A FlexDCA software controls the N1094A/B over a simple USB 2.0 or 3.0 connection.

Controlling the N1094A/B

There are three ways to control the N109X system:

- A PC directly connected to the N109X with a USB cable.
- An 86100D or N1000A mainframe connected to the N109X with a USB cable. (The mainframe can then be controlled via GPIB or LAN).
- For an automated test system environment, the simplest and preferred method to control the N109X is to connect the primary test system PC to a low-cost modern PC via LAN. The FlexDCA interface resides on the second PC. The second PC is then connected to the N109X via USB. This eliminates most issues of compatibility between an existing test system PC and the N109X hardware and can greatly simplify converting an 86100D system to an N109X system.

Connection schemes

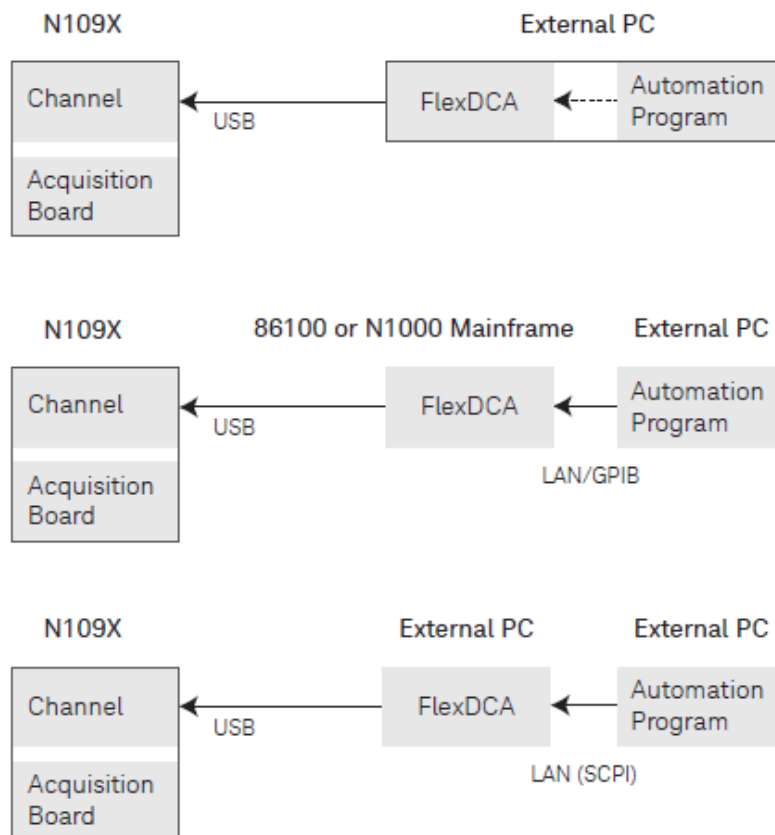

Figure 1. Connection Schemes

System setup

The following guidelines indicate the fundamental requirements for PC's connected to the N109X and running the FlexDCA interface:

For a single channel setup:

- Intel I3 processor or better
- 4 GB memory
- Windows 7 (32 or 64 bit)

For a parallel test setup (multiple instruments or multiple channels)

- Intel I5 or better
- 8 GB memory
- Windows 7 (64 bit)

The communication API between your system controller and the PC is SCPI over LAN, either VXI-11 or HiSlip. If NI-VISA or IO Libraries are used to communicate with GPIB instruments, the switch to SCPI/LAN is very simple. It is important to note that there is no need to do any USB programming. This is all handled by the FlexDCA interface.

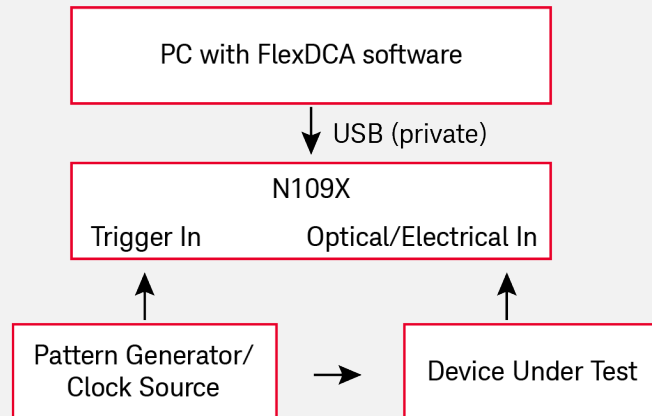

Figure 2. N1090X System Setup

The FlexDCA interface is free and can be downloaded at www.keysight.com/find/flexdca_download. Remote programs previously developed using the 86100 or N1000 FlexDCA interface can be leveraged directly to control an automated N109X system. Use FlexDCA SCPI programming tools to simplify conversion of legacy 86100-based automation to FlexDCA compatible code. Measurement results are generally faster with the new N109X due to significantly faster sampling rates.

Similar to the 86100 and N1000, a reference clock, synchronous with the signal being measured, is required to trigger the N109X. Timebase calibration, previously performed at service centers, can now be performed by users, reducing cost of ownership and instrument down time.

N1094A/B Configurations

Model/Option Number	Description
N1094A	Dual electrical channel oscilloscope
N1094B	Quad electrical channel oscilloscope
N1094x-030	20 and 30 GHz bandwidth settings
N1094x-050	20, 33, 40 and 50 GHz bandwidth settings
N1094x-LOJ	Low jitter timebase
N1094x-STB	Standard timebase
N1094x-PLK	Pattern lock capability
N1094x-FS1	Fast sampling rate
N1094x-200	Enhanced jitter analysis software, fixed perpetual license ¹
N1094x-201	Advanced waveform analysis software, fixed perpetual license
N1094x-300	Advanced amplitude analysis/Rin/Q-Factor, fixed perpetual license ¹
N1094x-401	Advanced eye analysis software, fixed perpetual license
N1094x-500	Productivity package, fixed perpetual license
N1094x-9FP	PAM-N analysis software, fixed perpetual license
N1094x-TFP	IEEE TDECQ analysis, fixed perpetual license
N1094x-PLK	Pattern lock trigger hardware
N1094x-EFP	FlexEye independent channel acquisition and control
N1094x-SIM	InfiniiSim-DCA waveform transformation software, fixed perpetual license
N1094x-C0C	Certificate of calibration
N1094x-UK6	Commercial calibration certificate with test data
N1094x-1CM	Single instrument rack mount kit
N1094x-1CN	Dual instrument side-by-side rack mount kit

1. Requires option PLK.

N1094A/B Specifications

N1094A/B electrical channel specifications

Item	Description
Electrical Channel Count	2 (N1094A) 4 (N1094B)
Electrical Input Connectors	2.4 mm (m) bulkhead ¹
Bandwidth, 3 dB (user selectable)	
Option 030	20 GHz and 33 GHz ²
Option 050	20 GHz, 33 GHz, 40 GHz, and 50 GHz ²
Transition Time (10% to 90% calculated from TR = 0.35/BW)	
20 GHz BW	17.5 ps (Calculated)
33 GHz BW	10.6 ps (Calculated)
40 GHz BW	8.8 ps (Calculated)
50 GHz BW	7.0 ps (Calculated)
Channel-to-Channel Skew Range	±100 ps
RMS Noise	
20 GHz BW	275 μV (Characteristic)
33 GHz BW	420 μV (Characteristic)
40 GHz BW	450 μV (Characteristic)
50 GHz BW	500 μV (Characteristic)
RMS Noise (Maximum)	700 μV
Scale Factor (per division)	
Minimum	1 mV/division
Maximum	100 mV/division
DC Accuracy (V _{AVG} Measurement)	±2 mV ±4% (reading – offset) ±1.15 mV (Characteristic)
DC Offset Range (referenced to center of screen)	±500 mV
Input Dynamic Range (relative to channel offset)	±400 mV
Maximum Input Signal	± 2V (+16 dBm)
Input Impedance	50Ω (Characteristic)

¹ Option 030 is supplied with one 2.92 mm (f) to 2.40 mm (f), 50-Ohm 40 GHz adapter for each channel input.

² Tuned to be –3 dB (±measurement uncertainty) at stated bandwidth(s) using NIST traceable swept-sine test system.

Clock input specifications

Item	Description
Clock Input Non-destruct Voltage	1.4 Vp-p
Clock Input Frequency	500 MHz to 32 GHz (full rate or sub-rate clocks, pattern lock mode on or off)
	100 MHz to 500 MHz (sub-rate clocks only, pattern lock off, provided that the data rate exceeds 500 Mb/s and the clock divide ratio is a power of two)
Clock Input Sensitivity	200 mVp-p
Minimum Clock Slew Rate	0.5 V/ns
Nominal Input Impedance	50 Ω (AC coupled)
Clock Input Connector	2.92 mm (female)

Horizontal timebase specifications

Item	Description
Scale Factor	Full scale is ten divisions
Minimum	100 fs/div
Maximum	100 μ s/div
Sample Delay ¹	< 10 ns
Time Interval Accuracy (in pattern lock mode)	$\pm 0.3\%$ of $1/(\text{clock input frequency})$ or ± 1.2 ps (whichever is smaller) (Characteristic) ² ± 150 fs $\pm 1\%$ of $1/(\text{clock input frequency})$ or ± 4 ps (whichever is smaller) ³
Time Interval Accuracy (in clock trigger mode)	$\pm 0.3\%$ of timespan or ± 1.2 ps (whichever is smaller) (Characteristic) ² ± 150 fs $\pm 1\%$ of timespan or ± 4 ps (whichever is smaller) ³
Time Interval Resolution ⁴	(screen timespan)/(record length) or 50 fs, whichever is larger
Jitter ⁵	
Option STB	400 fs rms (Characteristic) 450 fs rms
Option LOJ	135 fs rms (Characteristic) 160 fs rms
Display Units	Bits or Time
Record length	16 to 131,072 samples. Increments of 1
Sample rate ⁶	
Standard	100 kHz
Option FS1	250 kHz

¹ Time delay between the front panel clock input and when a sample is taken on the front panel channel input.

² Dual marker measurement performed at a temperature within $\pm 1\text{C}$ of horizontal calibration temperature.

³ Dual marker measurement performed at a temperature within $\pm 5\text{C}$ of horizontal calibration temperature.

⁴ The time interval resolution is the smallest time spacing between two points.

⁵ Verified with a clock and signal slew rate greater than 45 mV/ps.

⁶ Each channel is sampled at the specified sample rate regardless of the number of active channels.

Environmental specifications

Item	Description
Use	Indoor
Temperature	
Operating	+10C to +40C (+50°F to +104°F)
Non-operating	-40C to +70C (-40°F to +158°F)
Altitude (Operating)	Up to 4,600 meters (15,000 ft)
Humidity ¹	Type tested at 95%, +40°C (non-condensing)
Volts-Amperes (VA) (<i>Characteristic</i>)	
N1094A	48 VA
N1094B	52 VA
Weight (<i>Characteristic</i>)	
N1094A	6.0 kg (13.4 lb)
N1094B	6.1 kg (13.6 lb)
Dimensions	
Without front connectors and rear feet	88.26 mm H x 207.40 mm W x 485 mm D (3.48 inch x 8.17 inch x 19.01 inch)
With front connectors and rear feet	103.31 mm H x 219.56 mm W x 517.80 mm D (4.07 inch x 8.64 inch x 20.39 inch)
With front cover and rear feet	110.18 mm H x 219.56 mm W x 550.71 mm D (4.34 inch x 8.64 inch x 21.68 inch)

1. Samples of this product have been type tested in accordance with the Keysight Environmental Test Manual and verified to be robust against the environmental stresses of Storage, Transportation and End-use; those stresses include but are not limited to temperature, humidity, shock, vibration, altitude and power line conditions. Test Methods are aligned with IEC 60068-2 and levels are similar to MIL-PRF-28800F Class 3.

N1094A/B LINE power specifications

Nominal voltage and/or range	100/120Vac, 50/60/400 Hz
	220/240Vac, 50/60 Hz
Power in Watts	290 Watts Maximum
The products can operate with mains supply voltage fluctuations up to $\pm 10\%$ of the nominal voltage.	

Ordering Information — N1094A/B

The legacy FlexDCA feature-based software options such as 200, 201, etc. have been replaced with the following new FlexDCA Sampling Oscilloscope Software Packages.

Keysight recommends the use of the FlexDCA software PACKAGES which can be installed on the PC controlling your DCA-M (they cannot be installed directly on the DCA-M).

The legacy FlexDCA feature-based software options such as 200, 201, etc. are available for a limited time and can be installed by the factory on your new DCA-M.

Support subscriptions are available for FlexDCA software PACKAGES which enable both bug fixes and new functionality. The software FEATURE-based options will get no new functionality.

N1010100A Research and Development Package for FlexDCA Sampling Oscilloscope Software

This package is Intended for R&D engineers who want to characterize their design and gain more insights into why a signal deviates from the expected performance.

N1010200A Manufacturing Package for FlexDCA Sampling Oscilloscope Software

This package focuses on cost of test in Optical Transceiver manufacturing applications with capabilities like RapidEye and FlexEye that enhance measurement speed and flexibility and includes measurements like TDECQ.

N1010300A Signal Integrity Package for FlexDCA Sampling Oscilloscope Software

This package adds powerful tools to measure impedances, transfer characteristics and S-parameter calculations to the basic TDR/TDT measurements.

Application Software

SW Application Model	SW Application Description <i>See the application software datasheet to confirm hardware requirements.</i>
N109228CA	Electrical TX Test SW for OIF-CEI-3.1
N109310CA	Electrical TX Test SW for SFF-8431 (SFP+)
D9010UDAA	User Defined Application Software (for DCA-X and RT Scopes)
N1091APCA	Electrical TX Test SW for IEEE 802.3ap/bj (10G/40G)
N1091BMCA	Electrical TX Test SW for IEEE 802.3bm
N1091BACA	Electrical TX Test SW for IEEE 802.3ba (40G/100G)
N1091BJCA	Electrical TX Test SW for IEEE 802.3bj (100G)
N1091BSCB	Electrical TX Test SW for IEEE 802.3bs/cd
N109256CB	Electrical TX Test SW for OIF-CEI-4.0
N1095BSCA	Optical TX Test SW for IEEE 802.3bs/cd
N1094BS1A	PAM4 Measurement Software Development Kit.